

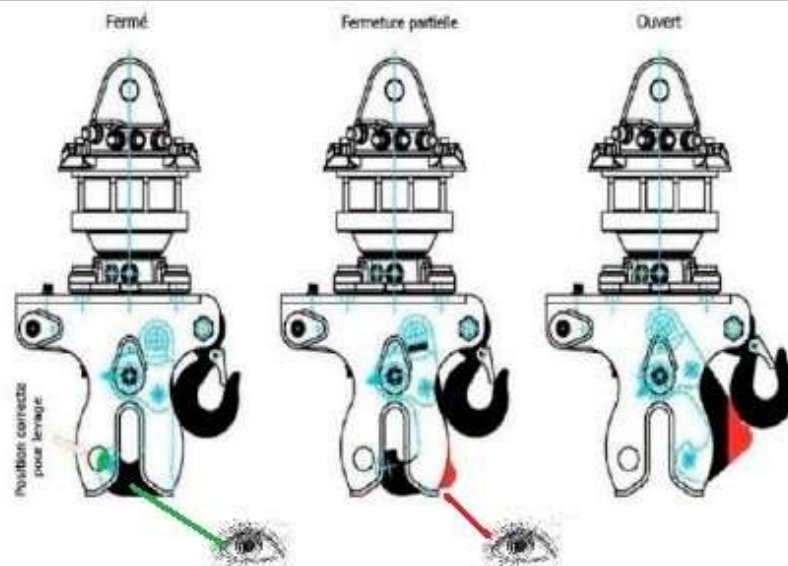

CROCHETS HYDRAULIQUES PGT

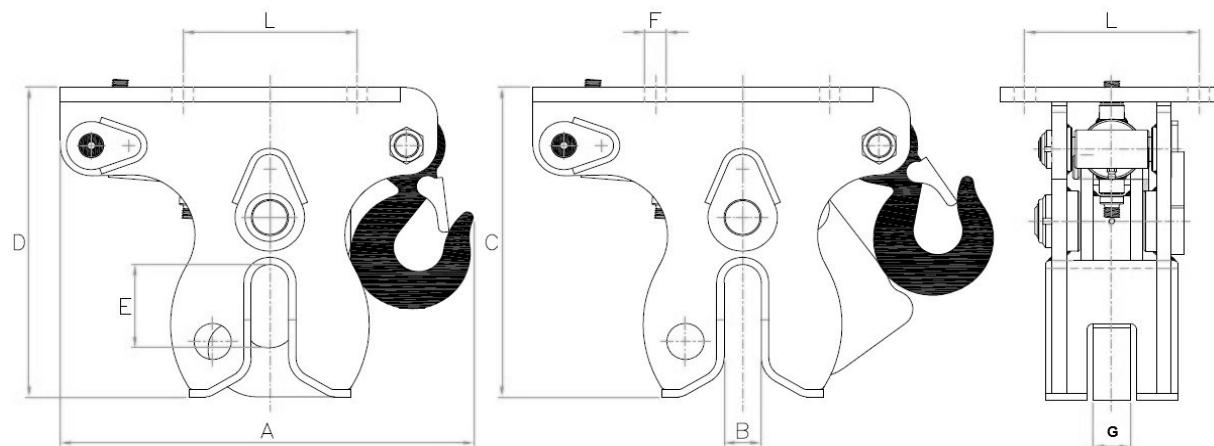

Type	Load en kg	Weight en kg	Pressure Max bar	Oil flow Lt/min	 Ton.	 Ton.	A en mm	B en mm	C en mm	D en mm	E en mm	F x L en mm	G en mm
PGT 331	3300	20	200	5	1,5-3,5	4,0-9,0	304	30	250	250	70	Ø17 x 140	24
PGT 451	4500	26	200	5	2,0-4,5	6,0-10	330	30	257	68	68	Ø17 x 140	30